

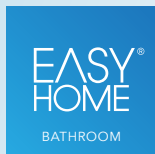

# Bedienungsanleitung Mode d'emploi Istruzioni per l'uso



## Sensor Abfallbehälter

Capteur poubelle | Sensore cestino per rifiuti



Deutsch..... 03  
Français..... 17  
Italiano ..... 31



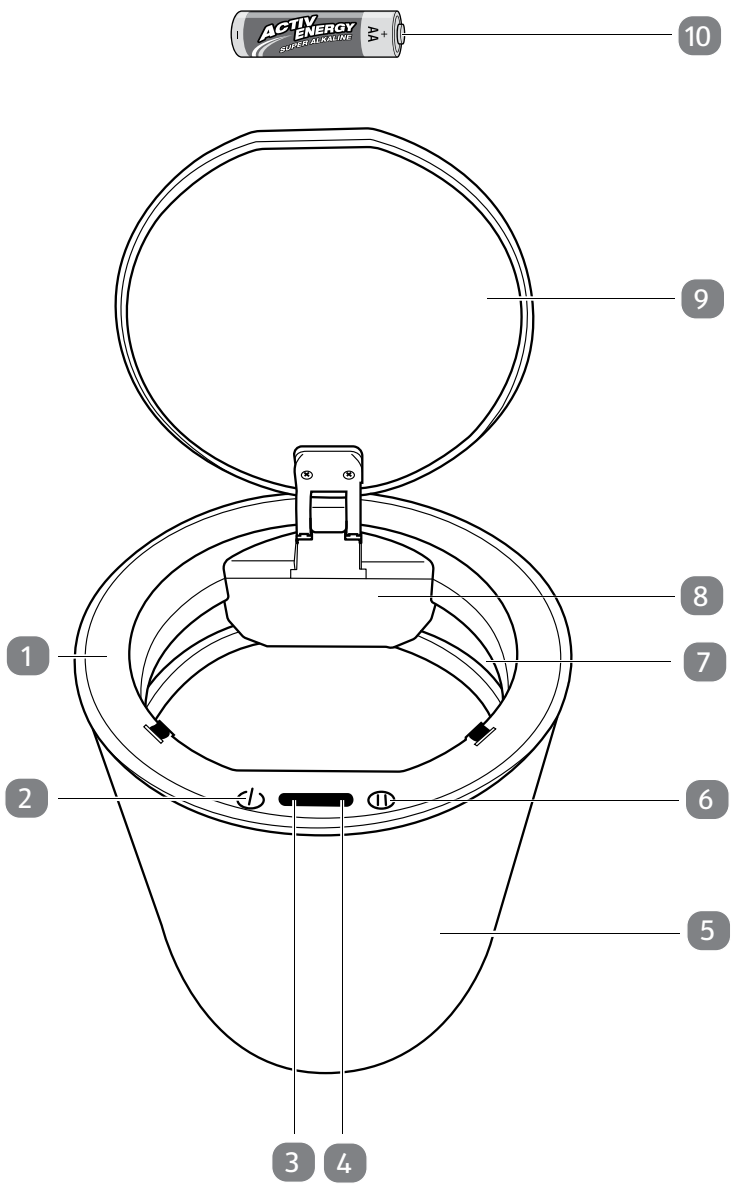



**Vertrieben durch: | Commercialisé par: |  
Commercializzato da:**

Jaxmotech GmbH  
Ostring 60  
66740 Saarlouis  
GERMANY

**KUNDENDIENST • SERVICE APRÈS-VENTE  
ASSISTENZA POST-VENDITA**

821772

Bitte wenden Sie sich an Ihre **ALDI SUISSE Filiale**.  
Veuillez vous adresser à votre **filiale ALDI SUISSE**.  
La preghiamo di rivolgersi alla sua **filiale ALDI SUISSE**.

MODELL / MODÈLE / MODELLO:  
TB 1707

02/2023

**3**

**JAHRE GARANTIE  
ANS GARANTIE  
ANNI GARANZIA**